

OKLAHOMA SCHOOL TESTING PROGRAM
OKLAHOMA CORE CURRICULUM TESTS

TEST AND ITEM
SPECIFICATIONS

Mathematics
Grade 7

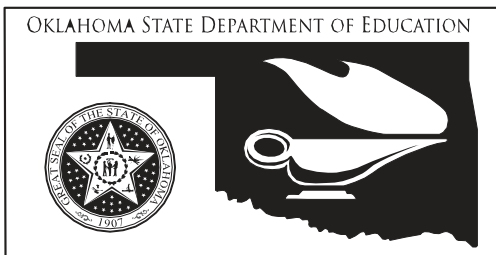
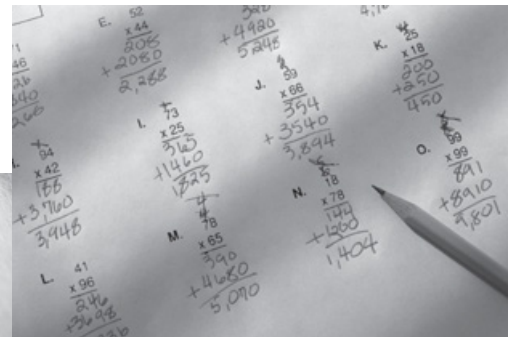
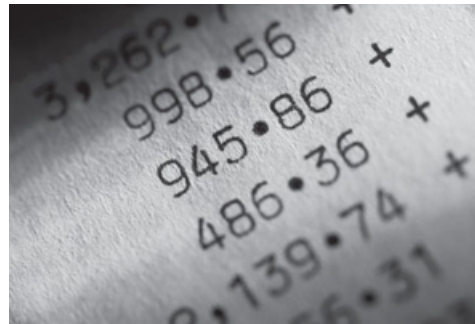

Oklahoma State Department of Education
Oklahoma City, Oklahoma

Revised
August 2013

OKLAHOMA CORE CURRICULUM TESTS

TEST AND ITEM SPECIFICATIONS

Table of Contents

Purpose.....	1
Test Structure, Format, and Scoring	2
Test Alignment with the Oklahoma Academic Standards.....	2
Test Blueprint	3
Depth of Knowledge Assessed by Test Items	4
Universal Test Design Considerations	5
Testing Schedules.....	5
Multiple-Choice Item Guidelines.....	6
Stimulus Materials.....	6
General Considerations.....	7
Vocabulary	8
Overview of Item Specifications	9
Mathematics Content Standards.....	10
Mathematics Process Standards.....	12
Sample Test Items by Standard.....	14

Purpose

The purpose of the Grade 7 Mathematics Test is to measure Oklahoma seventh-grade students' level of proficiency in mathematics. On the test, students are required to respond to a variety of items linked to the seventh-grade mathematics content standards identified in the Oklahoma Academic Standards (OAS). Each Mathematics Test form tests each identified content standard and objective listed below. The following standards and objectives are intended to summarize the knowledge as identified in the Oklahoma Academic Standards.

OAS Content Standards and Objectives
<p>Algebraic Reasoning: Patterns and Relationships</p> <ul style="list-style-type: none"> • Linear Relationships (1.1) • Solving Equations (1.2) • Solving and Graphing Inequalities (1.3)
<p>Number Sense and Operation</p> <ul style="list-style-type: none"> • Number Sense (2.1) • Number Operations (2.2)
<p>Geometry</p> <ul style="list-style-type: none"> • Classifying Figures (3.1) • Lines and Angles (3.2) • Transformations (3.3)
<p>Measurement</p> <ul style="list-style-type: none"> • Perimeter and Area (4.1) • Circles (4.2) • Composite Figures (4.3)
<p>Data Analysis</p> <ul style="list-style-type: none"> • Data Analysis (5.1) • Central Tendency (5.3) • Probability (5.3)



Test Structure, Format, and Scoring

The Oklahoma Core Curriculum Tests consist of multiple-choice items. Each multiple-choice item is scored as correct or incorrect. The student's raw score is converted to a scaled score using the number correct method. Of the total items, 10 items are field-test items and do not contribute to the student's scaled score.

Content Assessment	Total Items	Total Operational Items	Total Field Test Items
Mathematics	50	50	
Reading	50	50	
Geography	55	45	10

Test Alignment with the Oklahoma Academic Standards

Criteria for Aligning the Test with the OAS Standards and Objectives
<p>1. Categorical Concurrence The test is constructed so that there are at least six items measuring each OAS standard. The number of items is based on estimating the number of items that could produce a reasonably reliable estimate of a student's mastery of the content measured.</p>
<p>2. Depth of Knowledge Consistency The test is constructed using items from a variety of Depth of Knowledge levels that are consistent with the processes students need in order to demonstrate proficiency for each OAS objective.</p>
<p>3. Range of Knowledge Correspondence The test is constructed so that at least 75% of the objectives for an OAS standard have at least one corresponding assessment item.</p>
<p>4. Balance of Representation The test is constructed according to the Test Blueprint which reflects the degree of representation given on the test to each OAS standard and/or OAS objective in terms of the percent of total test items measuring each standard and the number of test items measuring each standard and/or objective. The test construction shall yield a balance of representation with an index of 0.7 or higher of assessed objectives related to a standard.</p>
<p>5. Source of Challenge Each test item is constructed in such a way that the major cognitive demand comes directly from the targeted OAS objective or OAS concept being assessed, not from specialized knowledge or cultural background that the test-taker may bring to the testing situation.</p>

**Oklahoma School Testing Program
Oklahoma Core Curriculum Tests
Grade 7 Mathematics
Test Blueprint
School Year 2013-2014**

The Test Blueprint reflects the degree to which each standard and objective of the Oklahoma Academic Standards is represented on the test. The overall distribution of operational items in a test form is intended to look as follows:

Standards and Objectives	Ideal Number of Items	Ideal Percentage of Items	Reporting Category
1.0 Algebraic Reasoning: Patterns and Relationships	15	30%	15
1.1 Linear Relationships	5		5
1.2 Solving Equations	5		5
1.3 Solving and Graphing Inequalities	5		5
2.0 Number Sense and Operation	11	22%	11
2.1 Number Sense	5		5
2.2 Number Operations	6		6
3.0 Geometry	8	16%	8
3.1 Classifying Figures	1-3		4
3.2 Lines and Angles	1-3		4
3.3 Transformations	4		4
4.0 Measurement	9	18%	9
4.1 Perimeter and Area	5		5
4.2 Circles	2		4
4.3 Composite Figures	2		4
5.0 Data Analysis	7	14%	7
5.1 Data Analysis	2		5
5.3 Central Tendency	3		5
5.2 Probability	2		2
Total Test	50	100%	50

- A minimum of 4 items is required to report results for an objective, and a minimum of 6 items is required to report a standard.
- Percentages are approximations and may result in a sum other than 100 due to rounding.
- Objectives have been grouped for reporting purposes only.
- The Oklahoma Academic Standards correspond to the *PASS* standards.

Depth of Knowledge Assessed by Test Items

The Oklahoma Core Curriculum Tests will, as closely as possible, reflect the following “Depth of Knowledge” distribution of items.

Grades 3-5	
Depth of Knowledge	Percent of Items
Level 1—Recall and Reproduction	20–25%
Level 2—Skills and Concepts	65–70%
Level 3—Strategic Thinking	5–15%

Grades 6-8	
Depth of Knowledge	Percent of Items
Level 1—Recall and Reproduction	10–15%
Level 2—Skills and Concepts	65–70%
Level 3—Strategic Thinking	15–25%

Level 1 (Recall and Reproduction) requires the student to recall facts, terms, definitions, or simple procedures, and to perform simple algorithms or apply formulas. One-step, well-defined, or straight algorithmic procedures should be included at this level.

Level 2 (Skills and Concepts) requires the student to make some decision as to how to approach the problem or activity. Level 2 activities include: making observations and collecting data; classifying, comparing, and organizing data; and organizing and displaying data in tables, charts, and graphs.

Level 3 (Strategic and Extended Thinking) requires complex reasoning, planning, developing, using evidence, and a higher level of thinking. These processes typically require an extended amount of time. The cognitive demands of the item should be high and the work should be complex. In order to be considered at this level, students are required to make several connections (relate ideas *within* the content area or *among* the content areas) and select one approach among many alternatives as to how the situation should be solved. Level 3 activities include: making conjectures; drawing conclusions from observations; citing evidence; developing a logical argument for concepts; explaining phenomena in terms of concepts; and using concepts to solve non-routine problems.

Note—The descriptions are adapted from Review Background Information and Instructions, Standards and Assessment Alignment Analysis, CCSSO TILSA Alignment Study, May 21–24, 2001, Version 2.0.

For an extended description of each Depth of Knowledge level, see the student assessment Web site at <<http://www.ok.gov/sde/>>.

Universal Test Design Considerations

Universal design, as applied to assessments, is a concept that allows the widest possible range of students to participate in assessments and may even reduce the need for accommodations and alternative assessments by expanding access to the tests themselves. In the Oklahoma Core Curriculum Tests, modifications have been made to some items that simplify and clarify instructions and provide maximum readability, comprehensibility, and legibility. This includes such things as reduction of language load in content areas other than Reading, increased font size, fewer items per page, and boxed items to assist visual focus. Reading tests will have vocabulary at grade level. In all other tests, the vocabulary level will be below the grade being tested except for content words. Grades 3 and 4 will be one grade level below, and grades 5, 6, 7, and 8 will be two grade levels below. These modifications are evident in the sample items included in this document.

Testing Schedules

Each subject test, except Writing, is divided into two separate sections at grades 3, 4, and 5. These two sections of the test may be administered on the same day with a break given between the sections or on consecutive days. At grades 6, 7 and 8, each subject area test is meant to be administered in a separate session. Students may be given additional time if needed, but additional time will be given as an extension of the same testing period, not at a different time.

Grade 7 Mathematics		Grade 7 Reading	
Test Session	<u>Approximately:</u>	Test Session	<u>Approximately:</u>
Distributing books, filling in the Student Demographic Page, reading directions	20 minutes	Distributing books, reading directions	15 minutes
Administering the Mathematics Test; no calculators are allowed during this test	60–80 minutes	Administering the Reading Test	95–115 minutes
Total:	80–100 minutes	Total:	110–130 minutes

Grade 7 Geography	
Test Session	<u>Approximately:</u>
Distributing books, filling in the Student Demographic Page, reading directions	20 minutes
Administering the Test	60–80 minutes
Total:	80–100 minutes

Multiple-Choice Item Guidelines

- All item stems clearly indicate what is expected in an item to help students focus on selecting a response.
- Each multiple-choice item has a stem (question, statement, or incomplete statement, and/or graphic component) and four answer (or completion) options, only one of which is correct.
- Multiple-choice item stems present a complete problem so that students know what to do before looking at the answer choices; students should not need to read all answer choices before knowing what is expected.
- Art incorporated within an item must be functional and assist students in determining the correct response.

In summary, test items assess whether students: understand relevant concepts and procedures; communicate their understandings effectively in content specific terms; approach problems; and develop viable solutions.

Stimulus Materials

Stimulus materials are the passages, graphs, models, figures, etc. that students must read and examine in order to respond to items. The following characteristics are necessary for stimulus materials:

1. When students are given information, data, or an experimental setup to evaluate, they should know the research question and the purpose of the research.
2. Tables, graphs, reading passages, and illustrations provide sufficient information for assessment of multiple standards.
3. Stimulus materials for a set of items may be a combination of multiple stimuli.
4. Information in stimulus materials is representative of concepts and principles described in the Oklahoma Academic Standards.
5. For conceptual items, stimulus materials are necessary but not conceptually sufficient for student response.
6. There is a balance of graphic and textual stimulus materials within a test form. At least 50% of the items have appropriate pictorial and graphical representations. Graphs, tables, or figures are clearly associated with their intended items. Graphics appear either on the same page as the stimulus or on the facing page.
7. The stimuli avoid subject matter that might prompt emotional distress on the part of the students.
8. Permission to use stimuli from copyrighted material is obtained as necessary by the testing vendor.

General Considerations

It is necessary to create test items that are reliable, fair, and targeted to the Oklahoma Academic Standards listed on the following pages. There are some general considerations and procedures for effective item development. These considerations include, but are not limited to, the following:

1. Each test form contains items assessing standards and objectives listed in the Test Blueprint for the specific grade and content area. In the Oklahoma Academic Standards document, asterisks have been used to identify standards and objectives that must be assessed by the local school district.
2. Test items that assess each standard are not limited to one particular type of response format. Each item begins with a stem that asks a question or poses a clear problem. Stems may include incomplete sentences in order to reduce unnecessary repetition of text.
3. Test items attempt to focus on content that is authentic and that grade-level students can relate to and understand.
4. Test items are worded precisely and clearly. The more focused an item, the more reliable and fair it will be, and the more likely all students will understand what is required of them.
5. All items are reviewed to eliminate language that is biased or is otherwise likely to disadvantage a particular group of students. That is, items do not display unfair representations of gender, race, ethnicity, disability, culture, or religion; nor do items contain elements that are offensive to any such groups.
6. All multiple-choice answer options, including the correct response and distractors, are similar in length and syntax. Students should not be able to rule out a wrong answer or identify a correct response solely because it looks or sounds different from the other answer choices. Distractors are created so that students reason their way to the correct answer rather than simply identify incorrect responses because of a distractor's obviously inappropriate nature. Distractors should always be plausible (but incorrect) in the context of the item stem. Correct responses are reasonably distributed among As, Bs, Cs, and Ds. The distractors adopt the language and sense of the material in the selection. Test items focus on reading skills and comprehension strategies, avoiding measurement of a student's feelings or values.
7. Items deal with issues and details that are of consequence in the stimulus and central to students' understanding and interpretation of the stimulus.
8. To the greatest extent possible, no item or response choice clues the answer to any other item. No item stem or answer option provides clues to any other item's answer, nor is the same fact of the passage assessed more than once, including the same vocabulary or technical term.
9. Test items are tied closely and particularly to the stimuli from which they derive, so that the impact of outside (prior) knowledge, while never wholly avoidable, is minimized.
10. The responses "Both of the above," "All of the above," "None of the above," and "Neither of the above" are not used.

11. Most stems are positively worded—avoiding the use of the word not. If a negative is required, the format is “All of the following . . .except.”
12. The material presented is balanced, culturally diverse, well-written, and of interest to students. The stimuli and items are presented fairly in order to gain a true picture of students’ skills.
13. Across all forms, a balance of gender and active/passive roles by gender is maintained.
14. No resource materials or calculators may be used by students during the test.

Vocabulary

No single source is available to determine the reading level of various words. Therefore, the appropriateness and difficulty of a word is determined in various ways. Vocabulary words are checked in the following: *EDL Core Vocabularies in Reading, Mathematics, Science, and Social Studies*; *Basic Reading Vocabularies*; the *Living Word*; or other reliable readability sources. In addition to using the aforementioned printed resources to assist in creating vocabulary items, each vocabulary item must be approved by Oklahoma’s Content Review Committee. The committee, comprised of Oklahoma educators from across the state, reviews proposed vocabulary items for grade level appropriateness. Reading tests will have vocabulary at grade level. In all other tests, the vocabulary level will be below the grade being tested except for content words. Grades 3 and 4 will be one grade level below, and grades 5, 6, 7, and 8 will be two grade levels below.

All items developed using these specifications are reviewed by Oklahoma educators and approved by the Oklahoma State Department of Education. The distribution of newly developed items is based on content and process alignment, difficulty, cognitive ability, percentage of art/graphics, and grade-level appropriateness as determined by an annual Item Development Plan approved by the Oklahoma State Department of Education.

Overview of Item Specifications

For each OAS standard, item specifications are organized under the following headings:

- OAS Standard and OAS Objective
- Item Specifications
 - a. Emphasis
 - b. Stimulus Attributes
 - c. Format
 - d. Content Limits
 - e. Primary Process Standards
 - f. Distractor Domain
 - g. Sample Test Items

The headings “OAS Standard” and “OAS Objective” state the standard and objective being measured as found in the seventh-grade mathematics section of the Oklahoma Academic Standards document.

The heading “Item Specifications” highlights important points about the items’ emphasis, stimulus attributes, format, content limits, primary process standards, distractor domain, and sample test items. Although it is sometimes possible to score single items for more than one concept, all items in these tests are written to address a single content standard as the primary concept.

Note about the Item Specifications and Sample Test Items:

With the exception of content limits, the item specifications give suggestions of what might be included and do not give an exhaustive list of what can be included. The sample test items are not intended to be definitive in nature or construction—the stimuli and the test items that follow them may differ from one test form to another, as may their presentations.

Oklahoma Academic Standards

MATHEMATICS CONTENT STANDARDS

Grade 7

Asterisks (*) have been used to identify standards and objectives that must be assessed by the local school district. All other skills may be assessed by the Oklahoma School Testing Program (OSTP).

Standard 1: Algebraic Reasoning: Patterns and Relationships—The student will use number properties and algebraic reasoning to identify, simplify, and solve simple linear equations and inequalities.

1. Identify, describe, and analyze functional relationships (linear and nonlinear) between two variables (e.g., as the value of x increases on a table, do the values of y increase or decrease, identify a positive rate of change on a graph and compare it to a negative rate of change).
2. Write and solve two-step equations with one variable using number sense, the properties of operations, and the properties of equality (e.g., $-2x + 4 = -2$).
3. Inequalities: Model, write, solve, and graph one-step linear inequalities with one variable.

Standard 2: Number Sense and Operation—The student will use numbers and number relationships to solve a variety of problems.

1. Number Sense
 - a. Compare and order positive and negative rational numbers.
 - b. Build and recognize models of perfect squares to find their square roots and estimate the square root of other numbers (e.g., the square root of 12 is between 3 and 4).
 - *c. Demonstrate the concept of ratio and proportion with models (e.g., similar geometric shapes, scale models).
2. Number Operations
 - a. Solve problems using ratios and proportions.
 - b. Solve percent application problems (e.g., discounts, tax, finding the missing value of percent/part/whole).
 - c. Simplify numerical expressions with integers, exponents, and parentheses using order of operations.

Standard 3: Geometry—The student will apply the properties and relationships of plane geometry in a variety of contexts.

1. Classify regular and irregular geometric figures including triangles and quadrilaterals according to their sides and angles.
2. Identify and analyze the angle relationships formed by parallel lines cut by a transversal (e.g., alternate interior angles, alternate exterior angles, adjacent, and vertical angles).
3. Construct geometric figures and identify geometric transformations on the rectangular coordinate plane (e.g., rotations, translations, reflections, magnifications).

Standard 4: Measurement—The student will use measurement to solve problems in a variety of contexts.

1. Develop and apply the formulas for perimeter and area of triangles and quadrilaterals to solve problems.
2. Apply the formula for the circumference and area of a circle to solve problems.
3. Find the area and perimeter of composite figures to solve application problems.

Standard 5: Data Analysis—The student will use data analysis, probability, and statistics to interpret data in a variety of contexts.

1. Data Analysis: Compare, translate, and interpret between displays of data (e.g., multiple sets of data on the same graph, data from subsets of the same population, combinations of diagrams, tables, charts, and graphs).
2. Probability: Determine the probability of an event involving “or”, “and”, or “not” (e.g., on a spinner with one blue, two red and two yellow sections, what is the probability of getting a red or a yellow?).
3. Central Tendency: Compute the mean, median, mode, and range for data sets and understand how additional data or outliers in a set may affect the measures of central tendency.

Oklahoma Academic Standards

MATHEMATICS PROCESS STANDARDS

Grade 7

Process Standard 1: Problem Solving

1. Develop and test strategies to solve practical, everyday problems which may have single or multiple answers.
2. Use technology to generate and analyze data to solve problems.
3. Formulate problems from situations within and outside of mathematics and generalize solutions and strategies to new problem situations.
4. Evaluate results to determine their reasonableness.
5. Apply a variety of strategies (e.g., restate the problem, look for a pattern, diagrams, solve a simpler problem, work backwards, trial and error) to solve problems, with emphasis on multistep and nonroutine problems.
6. Use oral, written, concrete, pictorial, graphical, and/or algebraic methods to model mathematical situations.

Process Standard 2: Communication

1. Discuss, interpret, translate (from one to another) and evaluate mathematical ideas (e.g., oral, written, pictorial, concrete, graphical, algebraic).
2. Reflect on and justify reasoning in mathematical problem solving (e.g., convince, demonstrate, formulate).
3. Select and use appropriate terminology when discussing mathematical concepts and ideas.

Process Standard 3: Reasoning

1. Identify and extend patterns and use experiences and observations to make suppositions.
2. Use counterexamples to disprove suppositions (e.g., all squares are rectangles, but are all rectangles squares?).
3. Develop and evaluate mathematical arguments (e.g., agree or disagree with the reasoning of other classmates and explain why).
4. Select and use various types of reasoning (e.g., recursive [loops], inductive [specific to general], deductive [general to specific], spatial, and proportional).

Process Standard 4: Connections

1. Apply mathematical strategies to solve problems that arise from other disciplines and the real world.
2. Connect one area or idea of mathematics to another (e.g., relate equivalent number representations to each other, relate experiences with geometric shapes to understanding ratio and proportion).

Process Standard 5: Representation

1. Use a variety of representations to organize and record data (e.g., use concrete, pictorial, and symbolic representations).
2. Use representations to promote the communication of mathematical ideas (e.g., number lines, rectangular coordinate systems, scales to illustrate the balance of equations).
3. Develop a variety of mathematical representations that can be used flexibly and appropriately (e.g., base-10 blocks to represent fractions and decimals, appropriate graphs to represent data).
4. Use a variety of representations to model and solve physical, social, and mathematical problems (e.g., geometric objects, pictures, charts, tables, graphs).

Oklahoma Academic Standards

Sample Test Items by Standard

Grade 7

OAS Standard:

Standard 1: Algebraic Reasoning: Patterns and Relationships—The student will use number properties and algebraic reasoning to identify, simplify, and solve simple linear equations and inequalities.

OAS Objective:

1. Identify, describe, and analyze functional relationships (linear and nonlinear) between two variables (e.g., as the value of x increases on a table, do the values of y increase or decrease, identify a positive rate of change on a graph and compare it to a negative rate of change).

Item Specifications:Emphasis:

Analyze the effect a change on one variable in a function has on the other variable in the function.

Stimulus Attributes:

Test items may include illustrations of the following: tables, coordinate graphs, and other diagrams.

Format:

- Analyze the relationship between two variables in an equation and the effect that a change in one variable has on the other.
- Describe the relationship between two variables in a function from real-world situations.

Content Limits:

- Limit change of slope to opposites, integers, and common fractions, or simple identification of steepness, or closer to vertical or horizontal (without calculation)
- Limit quadratic and exponential functions to graphic representations.

Primary Process Standards:

Process Standard 1: Problem Solving

Process Standard 2: Communication

Process Standard 3: Reasoning

Process Standard 4: Connections

Distractor Domain:

- Common errors
- Incorrect procedures
- Inappropriate operations with variables

Oklahoma Academic Standards 1.1 Sample Test Items:

Primary Process Standard: 7M2.1

Depth of Knowledge: 2

Correct Answer: B

x	y
-3	6
0	3
3	0
6	0

What happens to the value of y as the value of x increases?

- A** The value of y increases.
- B** The value of y decreases.
- C** The value of y stays the same.
- D** The value of y decreases and then increases.

Primary Process Standard: 7M2.1

Depth of Knowledge: 2

Correct Answer: A

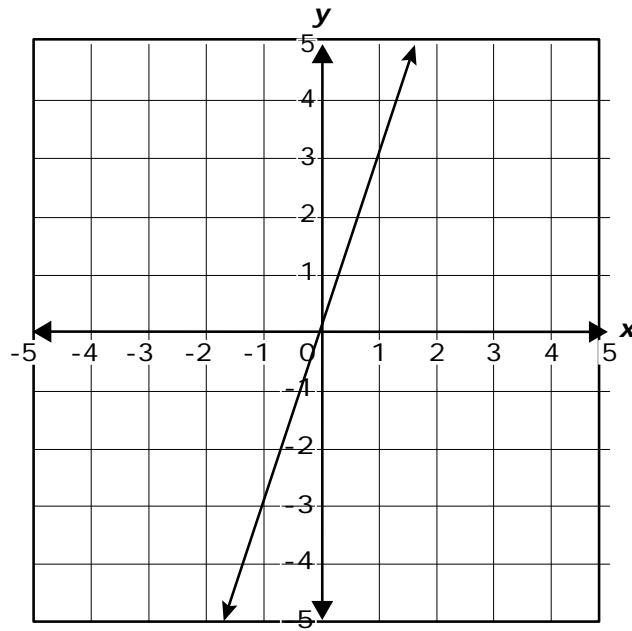

What is the equation of this graph?

- A $y = 3x$
- B $y = -3x$
- C $y = \frac{1}{3}x$
- D $y = -\frac{1}{3}x$

Primary Process Standard: 7M2.3

Depth of Knowledge: 1

Correct Answer: C

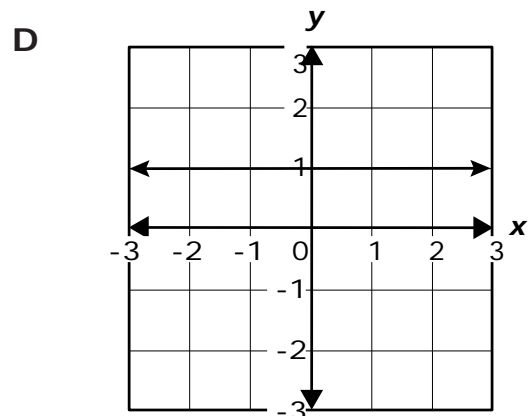
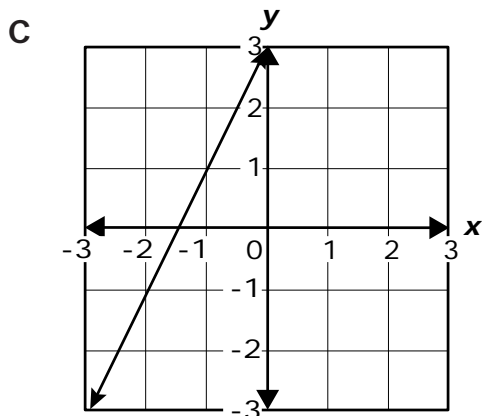
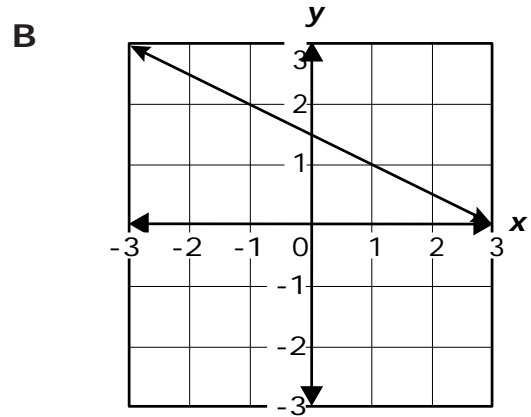
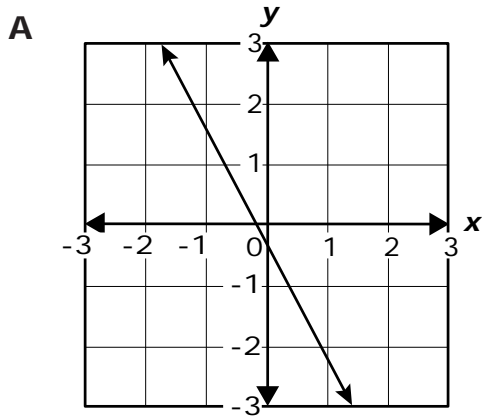
Which graph has a positive slope?

OAS Standard:

Standard 1: Algebraic Reasoning: Patterns and Relationships—The student will use number properties and algebraic reasoning to identify, simplify, and solve simple linear equations and inequalities.

OAS Objective:

2. Write and solve two-step equations with one variable using number sense, the properties of operations, and the properties of equality (e.g., $-2x + 4 = -2$).

Item Specifications:Emphasis:

Identify, translate, and analyze attributes of algebraic and geometric representations of lines; write and solve linear equations in mathematical and real-world situations.

Stimulus Attributes:

Test items may include illustrations of the following: coordinate graphs, number lines, balances, and other diagrams.

Format:

Identify, write, and solve 2-step linear equations involved in mathematical and real-world situations.

Content Limits:

- Limit linear equations to integer or common fraction coefficients

Primary Process Standards:

Process Standard 1: Problem Solving

Process Standard 4: Connections

Process Standard 5: Representation

Distractor Domain:

- Common errors
- Incorrect procedures
- Inappropriate operations with variables

Oklahoma Academic Standards 1.2 Sample Test Items:

Primary Process Standard: 7M1.5

Depth of Knowledge: 2

Correct Answer: C

$$4x - 10 = 18$$

What value of x makes this equation true?

- A 2
- B 4
- C 7
- D 8

Oklahoma Academic Standards 1.3 Sample Test Items:

Primary Process Standard: 7M1.5

Depth of Knowledge: 2

Correct Answer: A

$$2x + 3 = -13$$

What value of x makes this equation true?

- A -8
- B -5
- C 5
- D 8

Primary Process Standard: 7M5.1

Depth of Knowledge: 2

Correct Answer: A

Stacey earns \$15 plus \$2 for each newspaper she delivers each week. Which equation can Stacey use to find c , the number of customers she needs to earn \$25 each week?

A $2c + 15 = 25$

B $15c + 2 = 25$

C $17c = 25$

D $2c = 25$

OAS Standard:

Standard 1: Algebraic Reasoning: Patterns and Relationships—The student will use number properties and algebraic reasoning to identify, simplify, and solve simple linear equations and inequalities.

OAS Objective:

3. Inequalities: Model, write, solve, and graph one-step linear inequalities with one variable.

Item Specifications:Emphasis:

Identify, solve, and graph the solutions to one-step linear inequalities.

Stimulus Attributes:

Test items may include illustrations of the following: number lines, balances, and other diagrams

Format:

- Solve and graph the solution to a one-step linear inequality
- Identify one-step inequalities that model mathematical and real-world situations

Content Limits:

- Limit inequalities to one step
- Limit inequalities to one variable
- Limit coefficients to integers or common fractions
- Limit multiplication and division to positive rational numbers
- No Compound inequalities.

Primary Process Standards:

Process Standard 1: Problem Solving

Process Standard 2: Communication

Process Standard 5: Representation

Distractor Domain:

- Common errors
- Incorrect procedures
- Inappropriate operations with variables

Oklahoma Academic Standards 1.3 Sample Test Items:

Primary Process Standard: 7M1.5

Depth of Knowledge: 1

Correct Answer: D

Which of these expresses all of the solutions to this inequality?

$$4x \geq 68$$

- A** $x > 64$
- B** $x \geq 64$
- C** $x > 17$
- D** $x \geq 17$

Primary Process Standard: 7M5.3

Depth of Knowledge: 1

Correct Answer: B

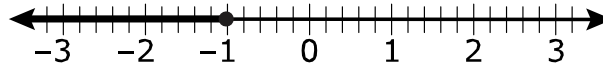
Which inequality represents the solution set shown on the number line?

- A** $n < -1$
- B** $n \leq -1$
- C** $n > -1$
- D** $n \geq -1$

Primary Process Standard: 7M5.2

Depth of Knowledge: 3

Correct Answer: A

A school science club has less than $\frac{4}{5}$ the number of members as the math club. If the science club has 16 members, which inequality represents m , all of the possible numbers of math club members?

- A $m > 20$
- B $m < 20$
- C $m > 13$
- D $m < 13$

OAS Standard:

Standard 2: Number Sense and Operation—The student will use numbers and number relationships to solve a variety of problems.

OAS Objective:

1. Number Sense
 - a. Compare and order positive and negative rational numbers.

Item Specifications:Emphasis:

Demonstrate an understanding of the structure of rational numbers

Stimulus Attributes:

Test items may include illustrations of the following: number lines and two- and three-dimensional geometric figures.

Format:

- Compare, order, and translate among representations of rational numbers

Content Limits:

- Limit mathematical and real-life contexts to age-appropriate situations
- Limit decimals to ten-thousandths
- Limit computations involving only fractions to halves, thirds, fourths, fifths, sixths, eighths, tenths, and twelfths

Primary Process Standards:

Process Standard 1: Problem Solving

Process Standard 2: Communication

Process Standard 4: Connections

Process Standard 5: Representation

Distractor Domain:

- Comparison errors

Oklahoma Academic Standards 2.1a Sample Test Items:

Primary Process Standard: 7M1.4

Depth of Knowledge: 1

Correct Answer: C

Maria recorded these temperatures during a science experiment.

-6 °F, -5.8 °F, -5.1 °F, -15 °F, -6.4 °F

Which list shows the temperatures in order from least to greatest?

A -5.1 °F, -5.8 °F, -6 °F, -6.4 °F, -15 °F

B -5.1 °F, -5.8 °F, -6.4 °F, -6 °F, -15 °F

C -15 °F, -6.4 °F, -6 °F, -5.8 °F, -5.1 °F

D -15 °F, -6 °F, -6.4 °F, -5.1 °F, -5.8 °F

Primary Process Standard: 7M4.2

Depth of Knowledge: 2

Correct Answer: C

The slopes of four hills are shown.

$$\frac{1}{2}, \frac{3}{5}, \frac{4}{6}, \frac{7}{12}$$

If the steepest slope is the greatest number, which slope is the steepest?

- A $\frac{1}{2}$
- B $\frac{3}{5}$
- C $\frac{4}{6}$
- D $\frac{7}{12}$

Primary Process Standard: 7M5.1

Depth of Knowledge: 2

Correct Answer: D

Adam, Dave, Kyla, and Dan gathered 100 eggs from the hen house. The table shows what part of the total each person gathered.

Eggs Gathered

Name	Part of the Total Gathered
Adam	$\frac{1}{4}$
Dave	0.31
Kyla	26%
Dan	$\frac{9}{50}$

Which lists the names in the order of the person who gathered the most eggs to the person who gathered the fewest eggs?

- A Dan, Adam, Kyla, Dave
- B Adam, Kyla, Dave, Dan
- C Kyla, Dave, Dan, Adam
- D Dave, Kyla, Adam, Dan

OAS Standard:

Standard 2: Number Sense and Operation—The student will use numbers and number relationships to solve a variety of problems.

OAS Objective:

1. Number Sense
 - b. Build and recognize models of perfect squares to find their square roots and estimate the square root of other numbers (e.g., the square root of 12 is between 3 and 4).

Item Specifications:Emphasis:

Demonstrate an understanding of perfect squares and square roots, and integers and approximate square roots through the use of models.

Stimulus Attributes:

Test items may include illustrations of the following: coordinate graphs, number lines, 10-by-10 grids, counting manipulatives, two-dimensional geometric figures, calculator displays, tables, graphs, charts, maps, scale drawings, data sets, and other diagrams.

Format:

- Use numbers to explore, estimate, and identify square roots and perfect squares in mathematical, geometric, and real-world contexts
- Use graphic representations including arrays and models of multiples to explore, estimate and identify square roots and perfect squares in mathematical, geometric, and real-world contexts

Content Limits:

- Limit graphic representations to common two-dimensional geometric figures
- Limit arrays to two-dimensional arrays

Primary Process Standards:

Process Standard 1: Problem Solving

Process Standard 3: Reasoning

Process Standard 5: Representation

Distractor Domain:

- Common errors
- Rounding errors
- Computational errors
- Incorrect use of rules or properties
- Use of incorrect equivalencies
- Incorrect interpretation of data display

Oklahoma Academic Standards 2.1b Sample Test Items:

Primary Process Standard: 7M5.3

Depth of Knowledge: 1

Correct Answer: A

Which model represents 3^2 ?**A** ● ● ●
● ● ●
● ● ●**B** ● ●
● ●
● ●**C** ● ● ● ●
● ● ● ●**D** ● ● ●
● ● ●

Primary Process Standard: 7M1.6

Depth of Knowledge: 2

Correct Answer: D

Which of these models can be used to represent the area of a square with a side length of $\sqrt{4}$?



Primary Process Standard: 7M1.1

Depth of Knowledge: 2

Correct Answer: B

The square root of 154 is between which two integers?

A 11 and 12

B 12 and 13

C 14 and 15

D 15 and 16

Primary Process Standard: 7M1.4

Depth of Knowledge: 2

Correct Answer: B

Which whole number is closest to the value of $\sqrt{126}$?

A 10

B 11

C 12

D 13

Primary Process Standard: 7M5.4

Depth of Knowledge: 2

Correct Answer: D

Which model is shaded to represent $\sqrt{144}$?

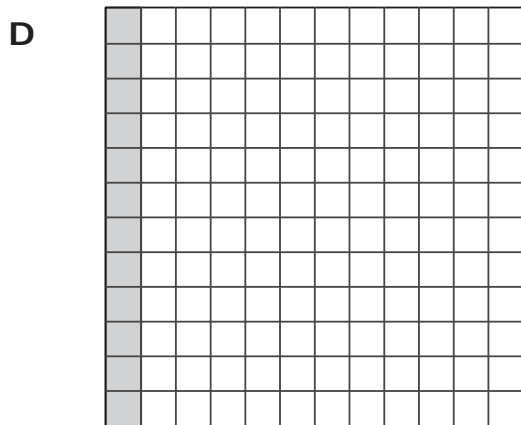
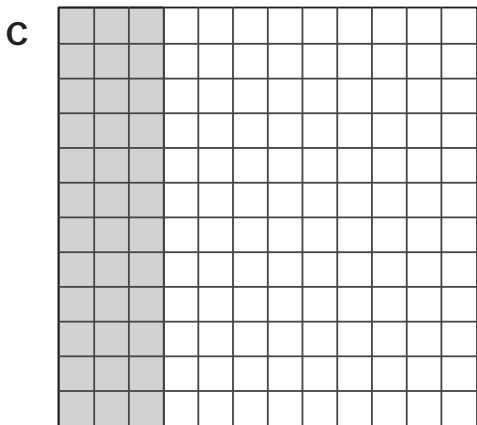
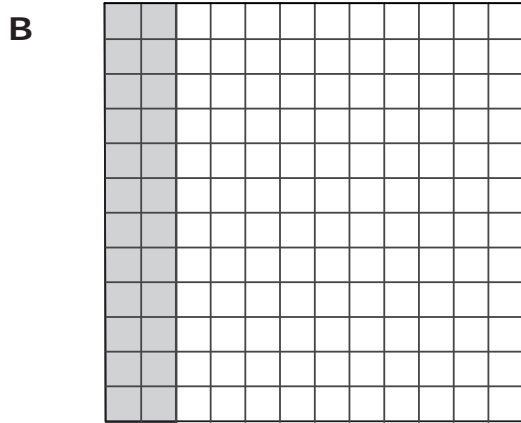
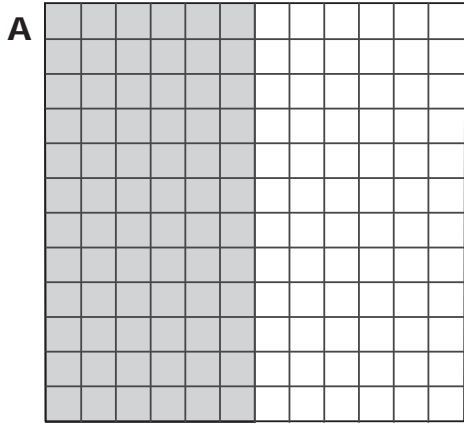

Primary Process Standard: 7M5.3

Depth of Knowledge: 3

Correct Answer: D

Josh has 56 identical square tiles. Which change would best allow Josh to combine all of the square tiles he has to create a single square?

- A** adding 6 tiles to the 56 he has
- B** adding 7 tiles to the 56 he has
- C** subtracting 6 tiles from the 56 he has
- D** subtracting 7 tiles from the 56 he has

Primary Process Standard: 7M3.1

Depth of Knowledge: 3

Correct Answer: D

Which point is closest to the value of $\sqrt{905}$ on the number line?

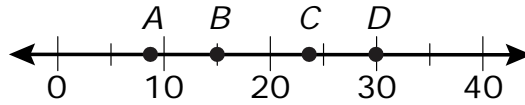

A point A

B point B

C point C

D point D

OAS Standard:

Standard 2: Number Sense and Operation—The student will use numbers and number relationships to solve a variety of problems.

OAS Objective:

2. Number Operations
 - a. Solve problems using ratios and proportions.

Item Specifications:Emphasis:

Demonstrate the ability to use ratio and proportion to estimate and solve mathematical and real world problems.

Stimulus Attributes:

Test items may include: illustrations of coordinate graphs, number lines, balances, two- and three-dimensional geometric figures; illustrations of rulers, thermometers, beakers, and other measuring instruments; calculator displays, tables, graphs, charts, maps, scale drawings, frequency charts; line, bar, and picture graphs; Venn diagrams; stem-and-leaf plots, box-and-whisker plots, scatter plots; histograms, data sets, spinners, and other diagrams.

Format:

- Select and apply ratios and proportions to solve problems in mathematical, geometric, and real-world contexts

Content Limits:

- Limit number of variables in a proportion to one
- Limit real-world contexts to age-appropriate situations

Primary Process Standards:

Process Standard 1: Problem Solving

Process Standard 4: Connections

Distractor Domain:

- Common errors
- Incorrect procedures
- Computational errors
- Incorrect use of rules or properties

Oklahoma Academic Standards 2.2a Sample Test Items:

Primary Process Standard: 7M1.6

Depth of Knowledge: 2

Correct Answer: D

There are 42 students in Kim's band class. Of those students, 31 are girls. Which proportion can be used to find x , the percent of students in the class that are boys?

A $\frac{31}{42} = \frac{x}{100}$

B $\frac{11}{31} = \frac{x}{100}$

C $\frac{31}{11} = \frac{x}{100}$

D $\frac{11}{42} = \frac{x}{100}$

Primary Process Standard: 7M1.1

Depth of Knowledge: 2

Correct Answer: B

The ratio of time Tim spends on math homework to science homework is 5 to 4. If he spends 40 minutes on math homework, how many minutes does he spend on science homework?

- A** 20 minutes
- B** 32 minutes
- C** 60 minutes
- D** 90 minutes

Primary Process Standard: 7M1.1

Depth of Knowledge: 3

Correct Answer: B

A machine in a factory capped 14 bottles in 84 seconds. How many bottles will the machine cap in 2 minutes working at this same rate?

- A** 16 bottles
- B** 20 bottles
- C** 28 bottles
- D** 35 bottles

OAS Standard:

Standard 2: Number Sense and Operation—The student will use numbers and number relationships to solve a variety of problems.

OAS Objective:

2. Number Operations
 - b. Solve percent application problems (e.g., discounts, tax, finding the missing value of percent/part/whole).

Item Specifications:Emphasis:

Demonstrate the ability to solve percent application problems in mathematical and real-world contexts.

Stimulus Attributes:

Test items may include: illustrations of coordinate graphs, number lines, balances, two- and three-dimensional geometric figures; illustrations of rulers, thermometers, beakers, and other measuring instruments; calculator displays, tables, graphs, charts, maps, scale drawings, frequency charts; line, bar, and picture graphs; Venn diagrams; stem-and-leaf plots, box-and-whisker plots, scatter plots; histograms, circle graphs, data sets, spinners, and other diagrams.

Format:

- Select and apply ratios and proportions among other methods to solve percent application problems in mathematical, geometric, and real-world contexts

Content Limits:

- Limit real-world contexts to age-appropriate situations
- Limit decimal points to the thousandths

Primary Process Standards:

Process Standard 1: Problem Solving

Process Standard 4: Connections

Distractor Domain:

- Common errors
- Incorrect procedures
- Computational errors
- Incorrect use of rules or properties
- Use of incorrect equivalencies

Oklahoma Academic Standards 2.2b Sample Test Items:

Primary Process Standard: 7M4.1

Depth of Knowledge: 2

Correct Answer: D

The Menendez family paid \$45 for a meal at a restaurant. They left a tip that was 20% of the cost of the meal. How much was the tip?

- A** \$0.20
- B** \$0.90
- C** \$2.00
- D** \$9.00

Primary Process Standard: 7M1.5

Depth of Knowledge: 3

Correct Answer: A

Steven earns \$12 an hour plus a 15% commission from every sale that he makes. During a two-week period, Steven worked 80 hours and made a total of \$1,300 in sales. What was the total amount of Steven's paycheck for the two-week period?

- A** \$1,155
- B** \$1,495
- C** \$2,260
- D** \$2,340

Primary Process Standard: 7M4.1

Depth of Knowledge: 3

Correct Answer: C

Bonnie's Furniture Store had a sale on Saturday. Every item was reduced by 15%. Mike purchased these items.

Original Prices

- one couch for \$199.99
- two tables for \$149.99 each
- one lamp for \$99.99

Which amount is closest to the total cost of Mike's purchases after the 15% discount and including the 6% sales tax?

- A** \$410
- B** \$510
- C** \$540
- D** \$640

OAS Standard:

Standard 2: Number Sense and Operation—The student will use numbers and number relationships to solve a variety of problems.

OAS Objective:

2. Number Operations
 - c. Simplify numerical expressions with integers, exponents, and parentheses using order of operations.

Item Specifications:Emphasis:

Demonstrate the ability to use the order of operations to find the value of a numerical expression.

Stimulus Attributes:

Test items may include illustrations of the following: tables, graphs, charts, data sets, equivalency statements, and algebraic expressions.

Format:

- Use the rules for order of operations with rational numbers to find the value of expressions
- Items may include exponents and parentheses

Content Limits:

- Limit exponents to whole numbers no greater than the third power

Primary Process Standards:

Process Standard 1: Problem Solving

Process Standard 3: Reasoning

Distractor Domain:

- Common errors
- Incorrect procedures
- Incorrect use of rules or properties
- Order of operations errors

Oklahoma Academic Standards 2.2c Sample Test Item:

Primary Process Standard: 7M1.5

Depth of Knowledge: 1

Correct Answer: D

$$21 - 36 \div (4 - 2^3)$$

What is the value of this expression?

- A** 4
- B** 12
- C** 18
- D** 30

OAS Standard:

Standard 3: Geometry—The student will apply the properties and relationships of plane geometry in a variety of contexts.

OAS Objective:

1. Classify regular and irregular geometric figures including triangles and quadrilaterals according to their sides and angles.

Item Specifications:Emphasis:

Demonstrate the ability to classify triangles and quadrilaterals based on sides and angles.

Stimulus Attributes:

Test items may include illustrations of the following: coordinate graphs, two-dimensional geometric figures, protractors, geoboards, other geometric manipulatives, tables, graphs, charts, maps, data sets, and other diagrams.

Format:

- Classify triangles according to their attributes
- Classify quadrilaterals according to their attributes

Content Limits:

Limit quadrilaterals to rectangles, squares, parallelograms, rhombi, and trapezoids.

Primary Process Standards:

Process Standard 1: Problem Solving
Process Standard 2: Communication
Process Standard 3: Reasoning
Process Standard 5: Representation

Distractor Domain:

- Common errors
- Incorrect procedures
- Incorrect use of rules or properties

Oklahoma Academic Standards 3.1 Sample Test Items:

Primary Process Standard: 7M2.3

Depth of Knowledge: 1

Correct Answer: B

**Leticia drew a triangle with exactly two sides of equal length.
What type of triangle did Leticia draw?**

- A** scalene
- B** isosceles
- C** equilateral
- D** equiangular

Primary Process Standard: 7M3.1

Depth of Knowledge: 1

Correct Answer: C

Which kind of triangle has angles with these three measures?

45° , 45° , and 90°

- A** equilateral
- B** obtuse
- C** right
- D** acute

Primary Process Standard: 7M2.3

Depth of Knowledge: 1

Correct Answer: B

Which term best describes this quadrilateral?



- A trapezoid
- B rectangle
- C rhombus
- D square

Primary Process Standard: 7M2.3

Depth of Knowledge: 2

Correct Answer: C

The figure shows a rectangle divided into two congruent triangles.

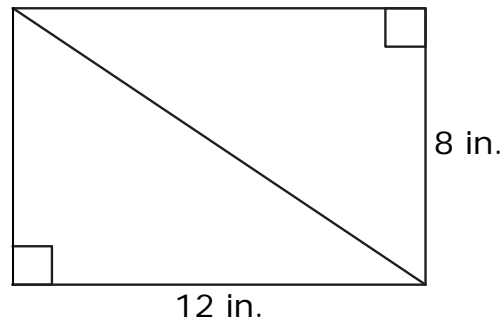

Which term best describes these triangles?

- A equilateral
- B isosceles
- C scalene
- D obtuse

Primary Process Standard: 7M3.1

Depth of Knowledge: 3

Correct Answer: D

Which type of triangle is always similar to all other triangles of the same type?

- A acute
- B right
- C scalene
- D equilateral

Primary Process Standard: 7M2.3

Depth of Knowledge: 3

Correct Answer: A

Penny drew a quadrilateral with these characteristics.

- all sides are of equal length
- the opposite sides are parallel
- two angles are acute

What type of quadrilateral did Penny draw?

- A** rhombus
- B** rectangle
- C** square
- D** trapezoid

OAS Standard:

Standard 3: Geometry—The student will apply the properties and relationships of plane geometry in a variety of contexts.

OAS Objective:

2. Identify and analyze the angle relationships formed by parallel lines cut by a transversal (e.g., alternate interior angles, alternate exterior angles, adjacent, and vertical angles).

Item Specifications:Emphasis:

Demonstrate a working knowledge of angle types and their measures in geometric figures and polygons.

Stimulus Attributes:

Test items may include illustrations of the following: coordinate graphs, two-dimensional geometric figures, protractors, geoboards, other geometric manipulatives, tables, graphs, charts, maps, data sets, and other diagrams.

Format:

- Identify and compare angles and angle relationships based on their positions in geometric figures, including the assessment of complementary and supplementary angles
- Find the measures of angles based on their positions and relationships in geometric figures

Content Limits:

- Limit geometric figures to two dimensions

Primary Process Standards:

Process Standard 1: Problem Solving

Process Standard 3: Reasoning

Process Standard 5: Representation

Distractor Domain:

- Common errors
- Incorrect procedures
- Computational errors
- Incorrect use of rules or properties

Oklahoma Academic Standards 3.2 Sample Test Items:

Primary Process Standard: 7M5.2

Depth of Knowledge: 1

Correct Answer: B

The drawing shows parallel lines l and m intersected by transversal t .

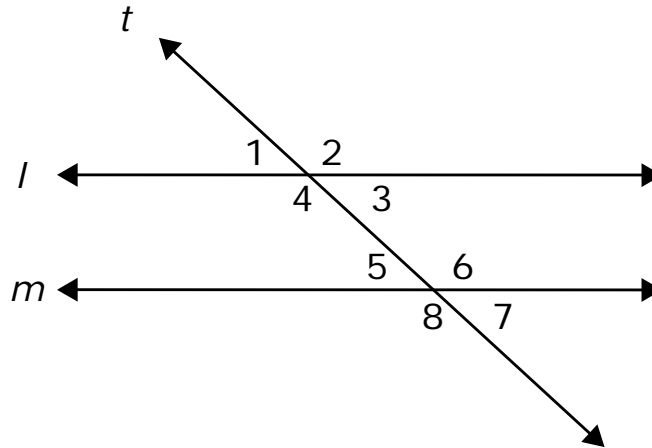

Which statement about angles 2 and 4 is true?

- A They are interior angles.
- B They are vertical angles.
- C They are corresponding angles.
- D They are complementary angles.

Primary Process Standard: 7M3.3

Depth of Knowledge: 1

Correct Answer: D

The drawing shows parallel lines l and m intersected by transversal t .

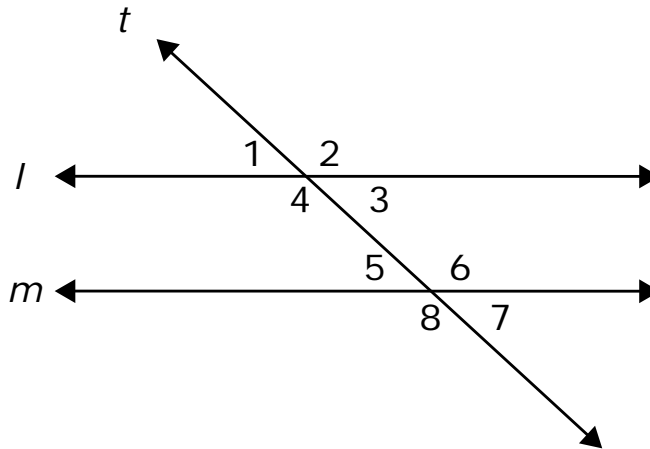

Which statement best describes angles 1 and 5?

- A They are interior angles.
- B They are vertical angles.
- C They are complementary angles.
- D They are corresponding angles.

Primary Process Standard: 7M3.3

Depth of Knowledge: 2

Correct Answer: B

Line l and line m are parallel. The measure of angle 1 is 45 degrees.

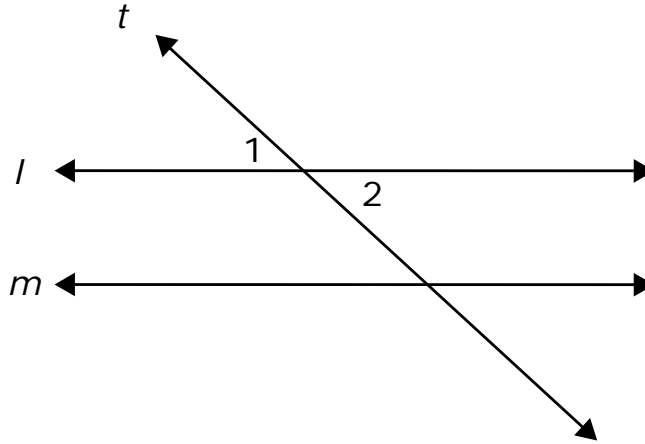

What is the measure of angle 2?

- A 35 degrees
- B 45 degrees
- C 55 degrees
- D 135 degrees

OAS Standard:

Standard 3: Geometry—The student will apply the properties and relationships of plane geometry in a variety of contexts.

OAS Objective:

3. Construct geometric figures and identify geometric transformations on the rectangular coordinate plane (e.g., rotations, translations, reflections, magnifications).

Item Specifications:Emphasis:

Demonstrate the ability to identify geometric transformations.

Stimulus Attributes:

Test items may include illustrations of the following: coordinate graphs, two-dimensional geometric figures, protractors, geoboards, other geometric manipulatives, tables, graphs, charts, maps, data sets, and other diagrams.

Format:

- Distinguish among transformations of figures on a coordinate plane and in real-world contexts

Content Limits:

- Limit geometric figures to two dimensions
- Limit transformations to reflections, rotations, translations, and dilations

Primary Process Standards:

Process Standard 1: Problem Solving

Process Standard 5: Representation

Distractor Domain:

- Common errors
- Incorrect procedures
- Confusion among geometric transformations

Oklahoma Academic Standards 3.3 Sample Test Items:

Primary Process Standard: 7M5.4

Depth of Knowledge: 2

Correct Answer: D

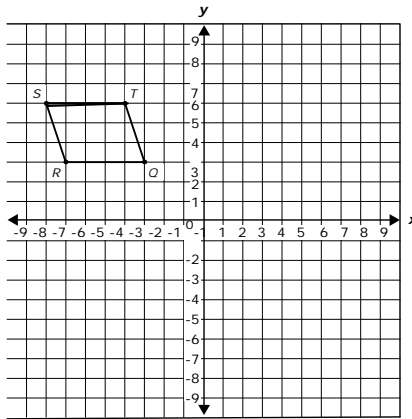

Which best shows the position of the parallelogram $QRST$ after it is reflected across the y -axis to form parallelogram $Q'R'S'T'$?

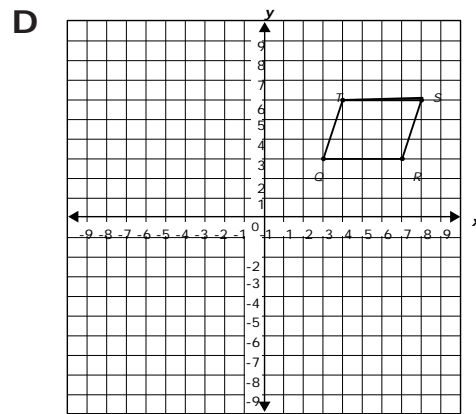
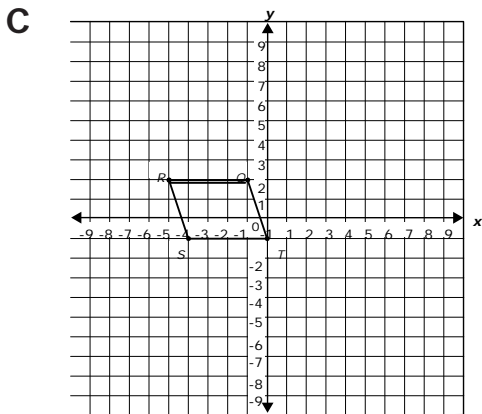
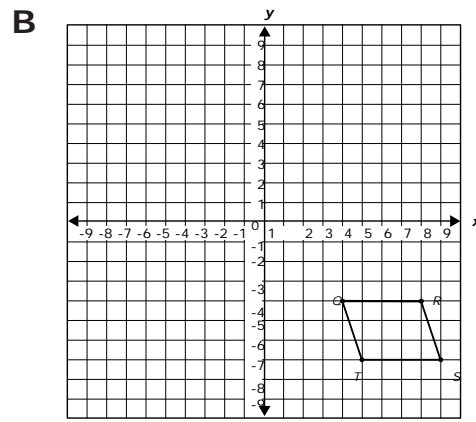
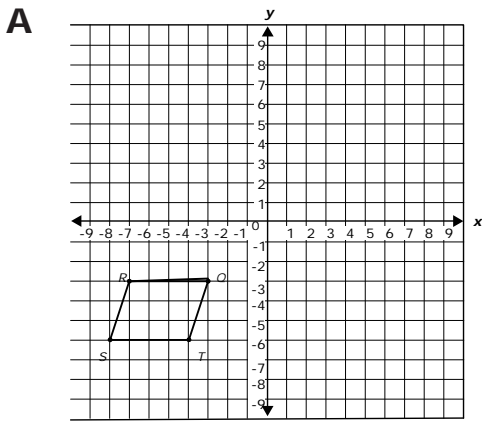

OAS Standard:

Standard 4: Measurement—The student will use measurement to solve problems in a variety of contexts.

OAS Objective:

1. Develop and apply the formulas for perimeter and area of triangles and quadrilaterals to solve problems.

Item Specifications:Emphasis:

Demonstrate the ability to estimate and solve area and perimeter problems for polygons.

Stimulus Attributes:

Test items may include illustrations of the following: coordinate graphs, two-dimensional geometric figures, rulers, calculator displays, tables, graphs, charts, combined forms, maps, scale drawings, frequency charts, data sets, formulas, and other diagrams.

Format:

- Apply the formulas used to find the area and perimeter of polygons in a variety of contexts
- Formulas may or may not be given

Content Limits:

- Limit figures to triangles and quadrilaterals or combinations of triangles and quadrilaterals

Primary Process Standards:

Process Standard 1: Problem Solving

Process Standard 3: Reasoning

Process Standard 4: Connections

Process Standard 5: Representation

Distractor Domain:

- Common errors
- Use of incorrect formula
- Confusion between area and perimeter
- Incorrect use of rules, properties, or formulas

Oklahoma Academic Standards 4.1 Sample Test Items:

Primary Process Standard: 7M5.4

Depth of Knowledge: 2

Correct Answer: C

Eli glued a piece of string along the perimeter of this figure.

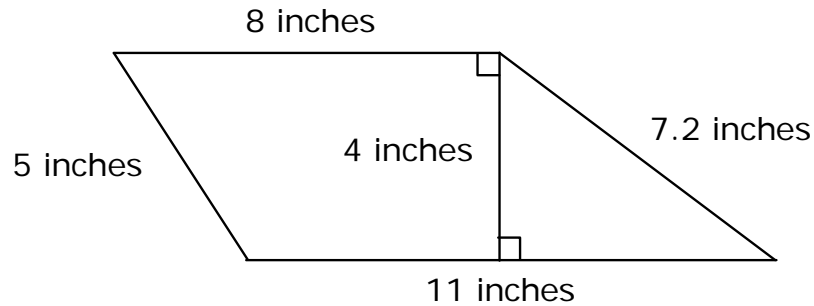

What is the smallest length of string Eli could use?

- A 24.2 inches
- B 25.2 inches
- C 31.2 inches
- D 35.2 inches

Primary Process Standard: 7M1.6

Depth of Knowledge: 2

Correct Answer: D

The figure shown is made up of line segments that meet at right angles.

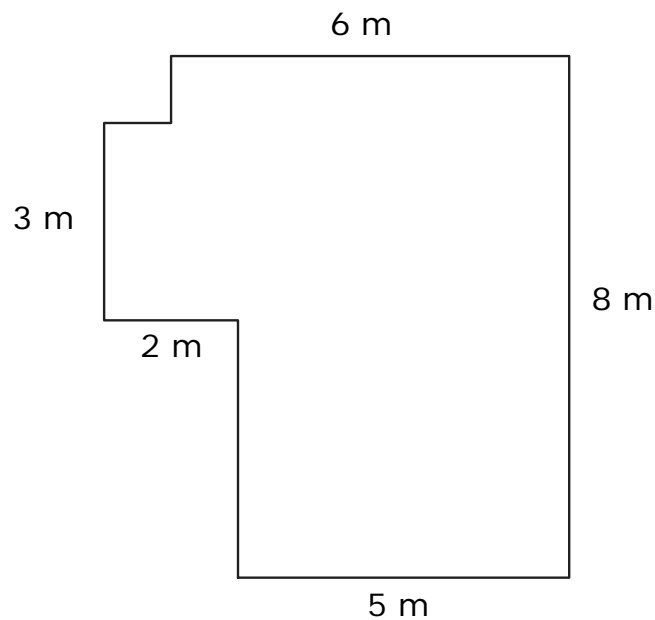

What is the perimeter of the figure in meters (m)?

- A 24 m
- B 26 m
- C 28 m
- D 30 m

Primary Process Standard: 7M1.6

Depth of Knowledge: 2

Correct Answer: A

The length of a rectangle is 18 inches. If the perimeter of the rectangle is 60 inches, what is the width, in inches (in.)?

- A** 12 in.
- B** 21 in.
- C** 24 in.
- D** 42 in.

OAS Standard:

Standard 4: Measurement—The student will use measurement to solve problems in a variety of contexts.

OAS Objective:

2. Apply the formula for the circumference and area of a circle to solve problems.

Item Specifications:Emphasis:

Demonstrate the ability to solve circumference and area problems for circles.

Stimulus Attributes:

Test items may include illustrations of the following: rulers, calculator displays, tables, graphs, charts, circles, formulas, and other diagrams.

Format:

- Apply the formula used to find the area and circumference of circles in a variety of contexts
- Formulas may or may not be given

Content Limits:

- Limit measurements of radius and diameter to rational numbers

Primary Process Standards:

Process Standard 1: Problem Solving

Process Standard 3: Reasoning

Process Standard 4: Connections

Process Standard 5: Representation

Distractor Domain:

- Incorrect procedures
- Computational errors
- Use of incorrect formula
- Confusion between area and circumference

Oklahoma Academic Standards 4.2 Sample Test Items:

Primary Process Standard: 7M1.1

Depth of Knowledge: 2

Correct Answer: C

Maria walked around a circular fountain one time. The radius of the fountain is 10 meters. What approximate distance did Maria walk around the fountain?

- A** 15 meters
- B** 31 meters
- C** 63 meters
- D** 314 meters

Primary Process Standard: 7M1.1

Depth of Knowledge: 1

Correct Answer: B

A circular track has a circumference of 200π meters. What is the radius of the circular track?

- A** 50 meters
- B** 100 meters
- C** 200 meters
- D** 400 meters

Primary Process Standard: 7M4.1

Depth of Knowledge: 3

Correct Answer: A

Tomas used a string with a piece of chalk tied to one end to draw a circle on the sidewalk. He held one end of the string on the sidewalk and then drew the circle using the chalk tied to the other end. The area of the circle was about 113 square inches. Which is closest to the length of the string?

$$A_{\text{circle}} = \pi r^2$$

- A 6 in.
- B 12 in.
- C 18 in.
- D 36 in.

OAS Standard:

Standard 4: Measurement—The student will use measurement to solve problems in a variety of contexts.

OAS Objective:

3. Find the area and perimeter of composite figures to solve application problems.

Item Specifications:Emphasis:

Apply formulas to find the area and perimeter of composite figures.

Stimulus Attributes:

Test items may include illustrations of two-dimensional geometric figures.

Format:

- Apply combinations of formulas to determine the area of irregular regions

Content Limits:

- Limit composite shapes to those made up of squares, rectangles, triangles, and circles
- Limit formulas to those used in real-world situations
- Limit multi-step processes to no more than two steps for each component stage

Primary Process Standards:

Process Standard 1: Problem Solving

Process Standard 2: Communication

Process Standard 3: Reasoning

Process Standard 4: Connections

Process Standard 5: Representation

Distractor Domain:

- Common errors
- Use of inappropriate formulas
- Incorrect procedures

Oklahoma Academic Standards 4.3 Sample Test Items:

Primary Process Standard: 7M4.2

Depth of Knowledge: 3

Correct Answer: A

The figure shown is made up of a rectangle and a semicircle.

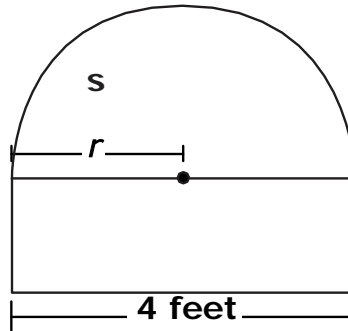

What is the area, in square feet (sq ft), of the semicircle?

$$A_{\text{circle}} = \pi r^2$$

- A 2π sq ft
- B 4π sq ft
- C 8π sq ft
- D 16π sq ft

Primary Process Standard: 7M3.4

Depth of Knowledge: 3

Correct Answer: A

The diagram shows isosceles triangle PQR . Each vertex of triangle PQR is a point on circle O .

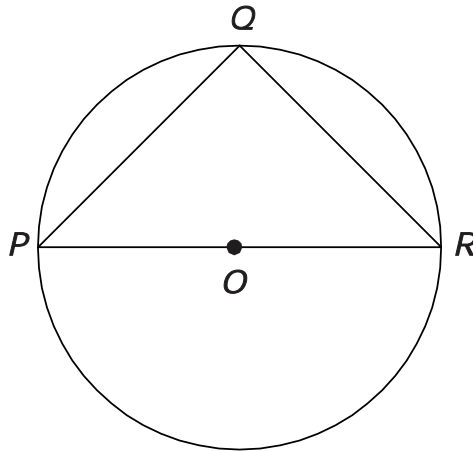

If the circumference of circle O is 10π units, what is the area of triangle PQR ?

$$C_{\text{circle}} = 2\pi r$$

$$A_{\text{triangle}} = \frac{1}{2}bh$$

- A 25π sq units
- B 30π sq units
- C 50π sq units
- D 100π sq units

OAS Standard:

Standard 5: Data Analysis—The student will use data analysis, probability, and statistics to interpret data in a variety of contexts.

OAS Objective:

1. Data Analysis: Compare, translate, and interpret between displays of data (e.g., multiple sets of data on the same graph, data from subsets of the same population, combinations of diagrams, tables, charts, and graphs).

Item Specifications:Emphasis:

Demonstrate knowledge of data representation through translation and comparison.

Stimulus Attributes:

Test items may include illustrations of the following: diagrams, tables, graphs, and charts.

Format:

- Translate between representations of data
- Compare how representations of data support inferences and predictions

Content Limits:

Limit correct graphs to charts, tables, bar graphs, pictographs, line graphs, circle graphs, and Venn diagrams.

Primary Process Standards:

Process Standard 1: Problem Solving

Process Standard 2: Communication

Process Standard 3: Reasoning

Process Standard 4: Connections

Process Standard 5: Representation

Distractor Domain:

- Misreported data
- Unsupportable conclusions
- Inappropriate representations

Oklahoma Academic Standards 5.1 Sample Test Items:

Primary Process Standard: 7M5.1

Depth of Knowledge: 1

Correct Answer: B

A group of seventh graders were surveyed about their favorite night to watch TV. This table shows the results of the survey.

TV Viewing

Night	Percent Favoring
Monday	50%
Tuesday	10%
Wednesday	10%
Thursday	25%
Friday	5%

Which graph shows the information from the table?

A TV Viewing

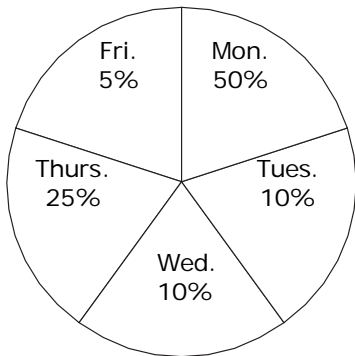

B TV Viewing

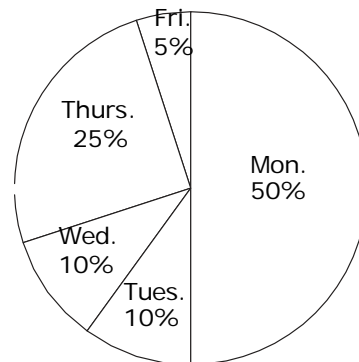

C TV Viewing

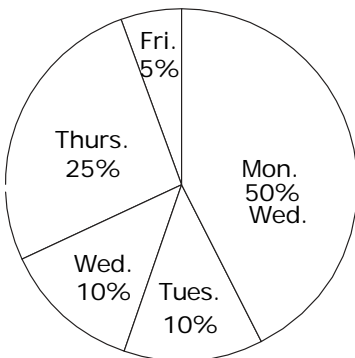

D TV Viewing

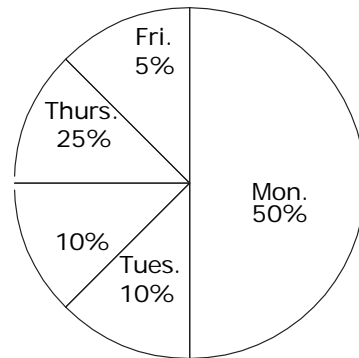

Primary Process Standard: 7M5.1

Depth of Knowledge: 2

Correct Answer: B

Jason recorded the high temperatures on school days last September. This table shows Jason’s results.

High Temperatures

Temperature (F°)	Number of Days
92	8
94	3
96	5
98	1
99	4

Which graph best shows the data in this table?

A High Temperatures

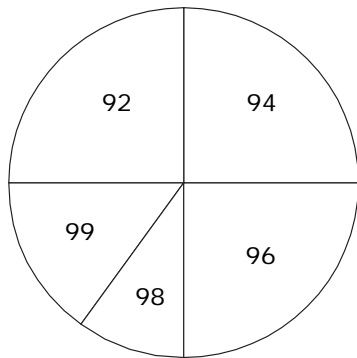

B High Temperatures

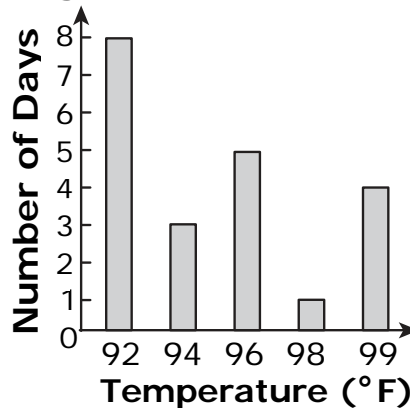

C High Temperatures

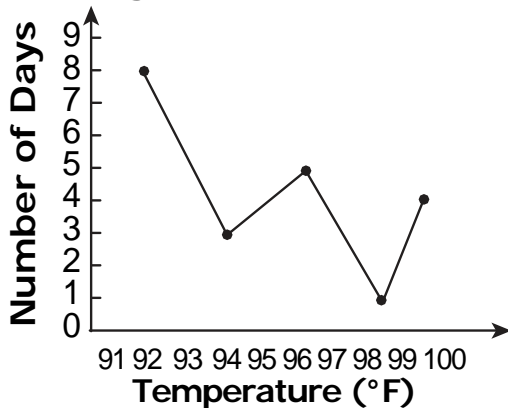

D High Temperatures

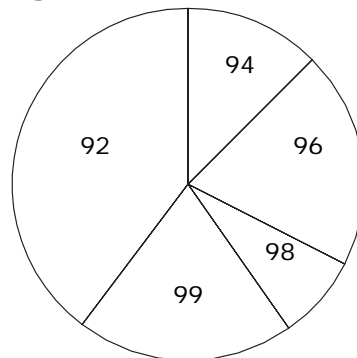

Primary Process Standard: 7M5.1

Depth of Knowledge: 2

Correct Answer: A

Kendra earns money for helping people in her neighborhood. The amount of pay Kendra earned for each week for 4 weeks is listed below.

- \$15 in week 1
- \$22 in week 2
- \$18 in week 3
- \$12 in week 4

Which graph best represents the pay Kendra earned for the 4 weeks?

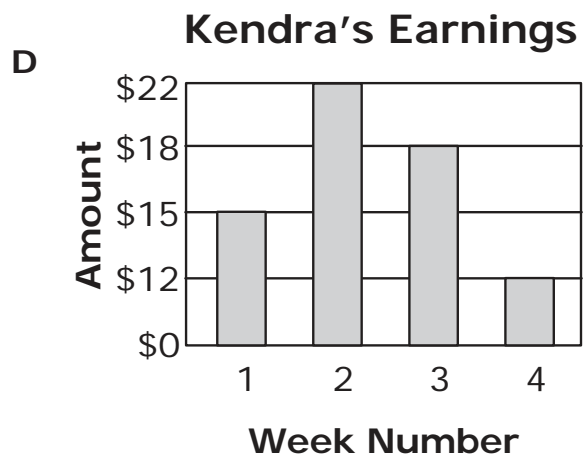
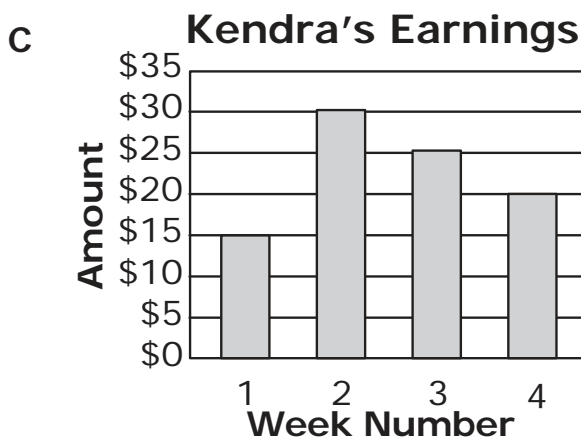
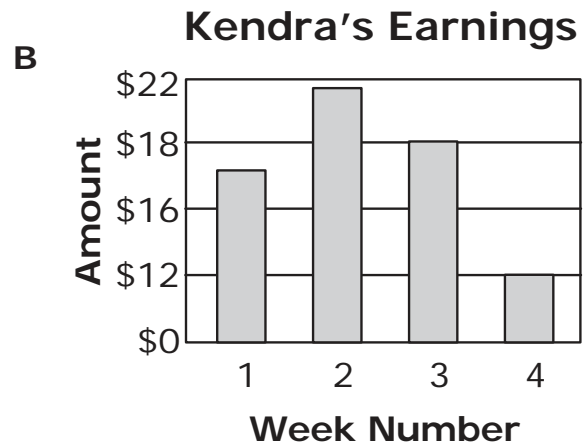
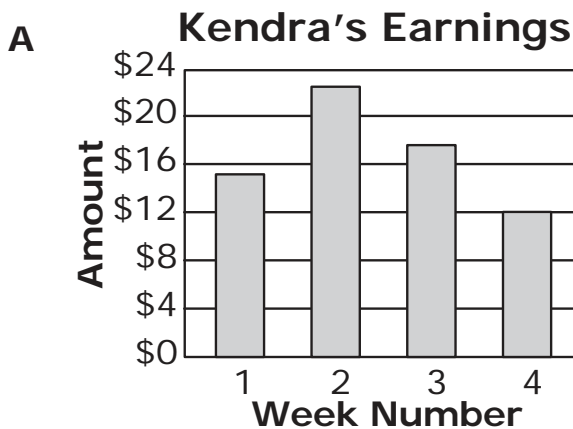

OAS Standard:

Standard 5: Data Analysis—The student will use data analysis, probability, and statistics to interpret data in a variety of contexts.

OAS Objective:

2. Probability: Determine the probability of an event involving “or”, “and”, or “not” (e.g., on a spinner with one blue, two red and two yellow sections, what is the probability of getting a red or a yellow?).

Item Specifications:Emphasis:

Demonstrate the ability to predict probabilities in specified mathematical and real-world contexts.

Stimulus Attributes:

Test items may include: illustrations of coordinate graphs, number lines, tables, graphs, and charts, such as frequency charts, line, bar, and picture graphs; Venn diagrams; stem-and-leaf plots, box-and-whisker plots, and scatter plots; histograms, circle graphs, data sets, spinners, and other diagrams.

Format:

- Predict the probability of the outcome of a specified event or experiment in a mathematical or real-world context based on “or,” “and,” or “not” statements
- Express probabilities in various forms, including decimal, fraction, and percent
- Probability can be with or without replacement.

Content Limits:

- Limit sample to no more than 20 pieces of data
- Limit real-world contexts to age-appropriate situations

Primary Process Standards:

Process Standard 1: Problem Solving

Process Standard 3: Reasoning

Process Standard 5: Representation

Distractor Domain:

- Common errors
- Incorrect procedures
- Computational errors
- Incorrect use of rules or properties
- Use of incorrect equivalencies

Oklahoma Academic Standards 5.2 Sample Test Items:

Primary Process Standard: 7M5.3

Depth of Knowledge: 2

Correct Answer: C

When Norma bought lunch at a restaurant, she was given a scratch-off game card with this statement:

1 out of 8 cards is a winner!

What is the probability that Norma did not receive a winning game card?

- A 8%
- B 12.5%
- C 87.5%
- D 92%

Primary Process Standard: 7M3.4

Depth of Knowledge: 2

Correct Answer: D

As part of a probability experiment, Susannah rolled two fair number cubes, one after the other. Each cube had its faces numbered 1 through 6. What is the probability that the first cube landed on 5 and the second cube landed on 6?

- A $\frac{1}{6}$
- B $\frac{1}{12}$
- C $\frac{1}{18}$
- D $\frac{1}{36}$

Primary Process Standard: 7M1.3

Depth of Knowledge: 2

Correct Answer: C

The prize wheel at the school fair is divided into 6 sections of equal size. The sections are numbered 1 through 6.

Prize Wheel

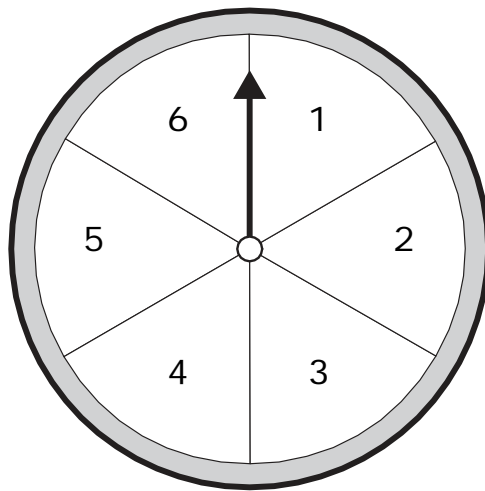

If the arrow is spun once, what is the probability that it will stop on a section labeled with an even number divisible by 3 or a section labeled with an odd number?

- A $\frac{1}{6}$
- B $\frac{1}{2}$
- C $\frac{2}{3}$
- D $\frac{5}{6}$

Primary Process Standard: 7M5.4

Depth of Knowledge: 2

Correct Answer: C

The graph shows the results of a survey given to a group of students.

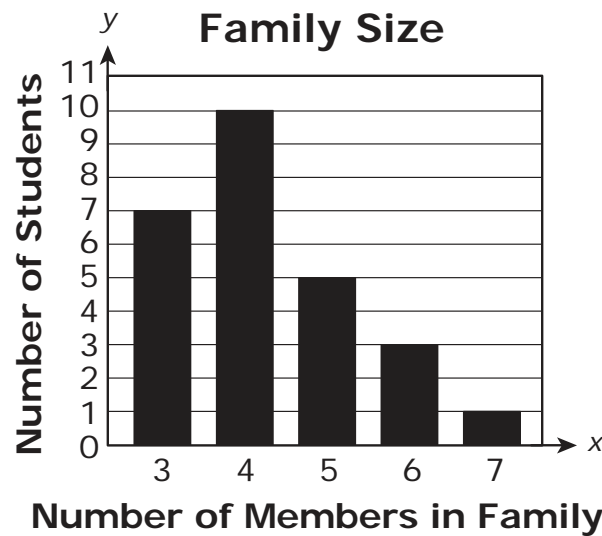

If one student is picked at random, what is the probability that the student has a family with 6 or 7 members?

- A $\frac{1}{26}$
- B $\frac{3}{26}$
- C $\frac{4}{26}$
- D $\frac{7}{26}$

Primary Process Standard: 7M5.4

Depth of Knowledge: 2

Correct Answer: B

Pam is playing a game with two spinners. One spinner has 3 sections of equal size, each labeled with a number 1 through 3. The other spinner has 5 sections of equal size, each labeled with a letter J through N. She drew this tree diagram to show the possible outcomes.

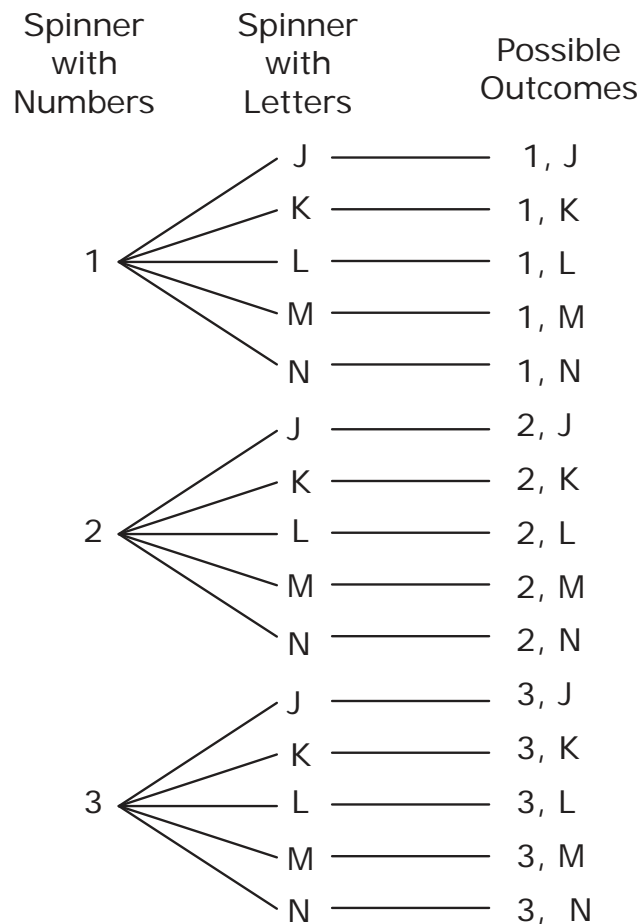

What is the probability of the arrow on either spinner landing on a 2 or a K on the next spin?

A $\frac{1}{5}$

B $\frac{7}{15}$

C $\frac{1}{3}$

D $\frac{5}{6}$

Primary Process Standard: 7M5.4

Depth of Knowledge: 2

Correct Answer: C

There are 20 students in Mr. Zapata's class. The Venn diagram shows the pets that some of the students have.

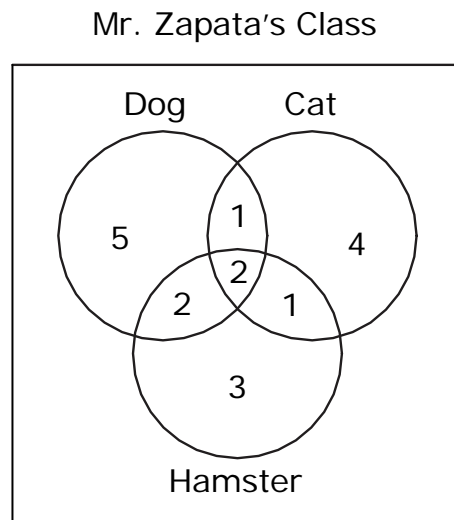

If Mr. Zapata chooses a student at random, what is the probability that the student has a dog or a cat?

- A $\frac{3}{20}$
- B $\frac{9}{20}$
- C $\frac{3}{4}$
- D $\frac{5}{6}$

OAS Standard:

Standard 5: Data Analysis—The student will use data analysis, probability, and statistics to interpret data in a variety of contexts.

OAS Objective:

3. Central Tendency: Compute the mean, median, mode, and range for data sets and understand how additional data or outliers in a set may affect the measures of central tendency.

Item Specifications:Emphasis:

Demonstrate an understanding of the mean, median, mode, and range of a set of data.

Stimulus Attributes:

Test items may include illustrations of the following: charts, tables, graphs, and data sets.

Format:

- Identify how measures of central tendency are affected by a change in a set of data
- Analyze the appropriate use of the mean in comparison with other measures of central tendency

Content Limits:

Limit data sets to at most 20 data points.

Primary Process Standards:

Process Standard 2: Communication

Process Standard 3: Reasoning

Distractor Domain:

- Common errors
- Incorrect procedures
- Use of wrong measure

Oklahoma Academic Standards 5.3 Sample Test Items:

Primary Process Standard: 7M3.1

Depth of Knowledge: 2

Correct Answer: B

18, 22, 20, 17, 28**If the number 21 is added to this set of data, how is the mean affected?**

- A** The mean increases by 1.
- B** The mean remains the same.
- C** The mean decreases by 1.
- D** The mean becomes the same as the mode.

Primary Process Standard: 7M3.4

Depth of Knowledge: 2

Correct Answer: B

Lin's first 4 quizzes had a mean score of 80%. If he scores 100% on his next quiz, what will be his mean quiz score for these 5 quizzes?

- A** 82%
- B** 84%
- C** 86%
- D** 90%

Primary Process Standard: 7M3.3

Depth of Knowledge: 2

Correct Answer: D

There are 5 students in Tamika's chorus group. The median score made by the group on the last test was 85. The scores for 4 students are shown.

85, 80, 95, 80

What could have been the score for the 5th student?

- A 70
- B 75
- C 80
- D 90

Primary Process Standard: 7M3.2

Depth of Knowledge: 3

Correct Answer: C

The table shows the number of meals sold in a school cafeteria to 7th graders each day for the first 4 days of a week.

**Cafeteria Meals Sold
to 7th Graders**

Day	Number of Meals
Monday	64
Tuesday	71
Wednesday	73
Thursday	60
Friday	?

If the mean number of meals sold for all 5 days was 69, how many meals did the cafeteria sell on Friday?

- A** 67 meals
- B** 69 meals
- C** 77 meals
- D** 82 meals